

DEBURRING TOOLS



► YABARI COMPENSATING DEBURRING TOOL

SPINDLE SPEED 10.000rpm
ROTATION : CLOCKWISE
FEED : 2000-4000 mm/min

.The holder has a top rated speed of 10.000min⁻¹

.The gripping range of the collet is $\varnothing 0.6$ to $\varnothing 7$ mm for ER11.

.Built-in mechanism to contract 10mm in the axial direction.

YABARI is capable of applying constant pressure of the cutting edge against the surface to deburr.

.YABARI has built-in load adjustment mechanism.



DEBURRING TOOLS



▶ YABARI PUSH TYPE COMPENSATING DEBURRING TOOL

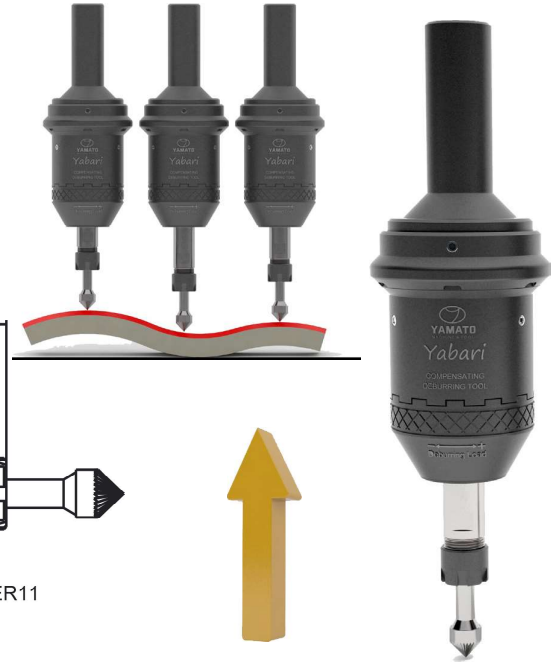
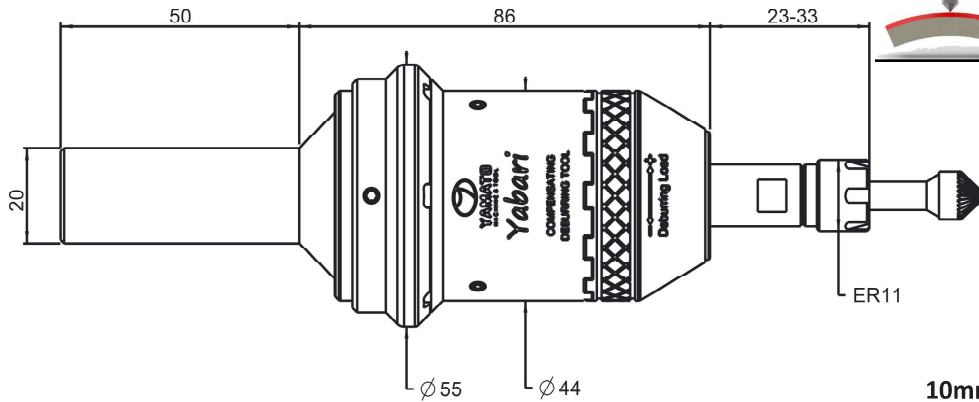

10mm AXIAL DEFLECTION PUSHING

▶ YABARI PULL TYPE COMPENSATING DEBURRING TOOL

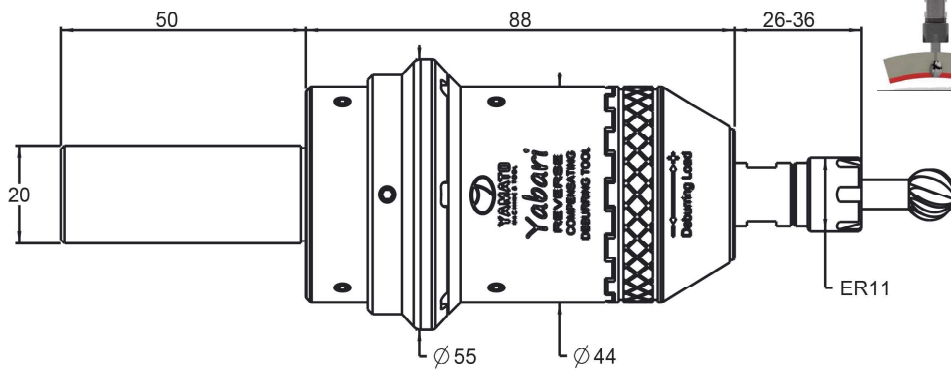

10mm AXIAL DEFLECTION-PULLING

Included Accessories:

-ER11 6mm collet -ERM11 nut -ERM11 spanner



YAMATO

6172/2 Sok. No:1/8
Isikkent /Izmir- TURKEY
Phone: +90.232.472 28 88
Fax: +90.232.472 28 90
info@yamato.com.tr
www.yamato.com.tr